Table of Contents

Complete Vehicle

Subject	Page
Complete Vehicle	4
History	4
Design	5
Vehicle Data	7
Technical Data	9
Body	10
Hood	10
Headlights	10
Front bumper	11
Plastic panel	12
Front side panels	12
Windscreen	13
Door mirrors	13
Door trim panel	13
Window regulator/door window glass	13
Handle/lock	14
Interior	15
Seats	15
Basic seat (electric)	15
Sport Seat	16
Control unit locations in passenger compartment	16
Engine compartment Control Units	18
Locations of control units in engine compartment	18
E85 Soft-top	19
Manual soft-top	19
Components	21
Rear window	21
Lowering the soft top	21
Raising the soft-top	21

Table of Contents

Subject	Page
Stowage compartment catch21
Releasing the stowage compartment catch:21
Service notes:22
Ordering spare parts:22
Adjusting the soft-top:22
Fully automatic soft-top23
Hydraulic pump unit23
Method of operation:24
Hydraulic servo units24
Preconditions for raising and lowering the soft-top24
Lowering the soft top25
Raising the soft top25
Easy Open function25
Easy Close function26
Emergency actuator26
Adjustment after soft-top removal/replacement:27
Variable-position soft-top stowage compartment base27
Hardtop28
Wind-break29
Roll-over bar trim panels29
Trunk30
Rear bumper30
Impact dampers (US version)30
Plastic panel31
Park Distance Control (PDC)31
Sidemarkers (US)31
Rear light clusters31
Rear light cluster surround32
Third brake light32
Review Questions33

Complete Vehicle

Model: E85

Production: Start of Production MY 2003

Objectives:

After completion of this module you should be able to:

- Locate the major control units in the car.
- Recognize the differences between the Z3 and the Z4.
- Explain basic vehicle operation.

Complete Vehicle

History

The E85 (Z4) is due to enter production around 09/2002 at the Spartanburg plant and will replace the E36/7 (Z3). In so doing it will be writing the next chapter in the history of the BMW roadster.

That tradition started with the historic 328 and 507 models and has been continued by the Z1, Z3 and Z8.

The latest model, the Z4 (development code E85), is being built only as a roadster. There will be no coupé as there was with the Z3. The 3.0i and the 2.5i versions of the Z4 will both be fitted with the M54 engine.

With a breathtaking, completely new design and even more sporting driving characteristics, it is intended to advance to a leading position with regard to dynamism among the competition. A range of equipment that is modern and suited to the market is the basis for successful higher placement in comparison to the Z3.

This higher placement is reinforced by the exclusive use of 6-cylinder engines as well as the new name (the Z3 becomes the Z4). In order to secure market leadership, the E85 features numerous technical gems, whereby the soft-top and audio systems were assigned particular attention during development; the Z4 is to be the "best in each class."

Different lines of equipment and the offer of virtually all special equipment that has so far been reserved for higher series (including High navigation with folding monitor) complete the image of the E85 as a premium model.

Alongside its breathtaking design in a completely new language of shape, the E85 also features a variety of technical innovations:

- Engine bonnet made of aluminum
- Completely new soft-top design with Z folding
- Soft-top rear window made of glass
- Top HiFi audio system with Carver woofers
- Engine Sound System MSS (only 3.0i)
- Emission-free fuel tank
- Electromechanical power-assisted steering (Electric Power Steering EPS)
- Standard tires with runflat tires, no spare wheel
- 6-speed manual gearbox (as of 12/2002)
- 6-speed H-SMG gearbox (as of 04/2003)

Design

The E85 features all of the proportions that are typical of a roadster: long engine hood, short rear and short overhangs. Both seats stretch far to the back - almost to the rear axle.

These basic characteristics lend the E85 an extravagant and futuristic appearance. The design does not adopt the same direction as the E65, but rather interprets the values of sporting character and dynamism by deliberately omitting classical luxury.

The use of "flame surfacing" for the first time makes the new BMW roadster into a breathtaking pioneer in a new era of design. The mix of curves and straight lines, crossing lines, concave and convex elements underlines this language of shape. Depending on the angle of view, the E85 reveals a wide variety of details to the beholder.

In comparison to the Z3, the front is smoother and rounder, but preserves the typical BMW characteristics of kidney grille and double headlights. The kidney grille has been lowered into the deforming elements made of yielding foam material. The turn indicator lamps extend across the entire lower edge of the front headlights (bi-Xenon as special equipment) up to the side top edge.



The side line continues the roundings of the front with a striking sweep. The front limit line of the engine bonnet runs across the headlight top edges into the vehicle flanks. There, it continues over the front mudguard in a curve all the way to the lower edge of the doors, which it closes off to the rear.

A slanted straight bead in front of the doors adopts the line of the A-pillars. It clearly delineates the front mudguards and is interrupted by a large BMW emblem, surrounded by the side turn indicator lamps. Although the soft-top lies open in the soft-top compartment, it is permanently covered and dirt-protected by means of the new Z folding by its own front third.



The highly expressive rear end is kept visually flat by means of the almost horizontal side lines. Together with the rear lights cut straight at the top and curved at the bottom, the E85 radiates just as much dynamism and activity from the rear as it does from the front. The centre brake light is inserted beneath the striking cut edge of the luggage compartment lid. The wheels deployed are exclusively light-alloy wheels, initially with 6 different rim designs with 16, 17 or 18 inches diameter.



Vehicle Data



Abb. 16: Garagenzeichnung vorn/hinten





Abb. 18: Garagenzeichnung Seite

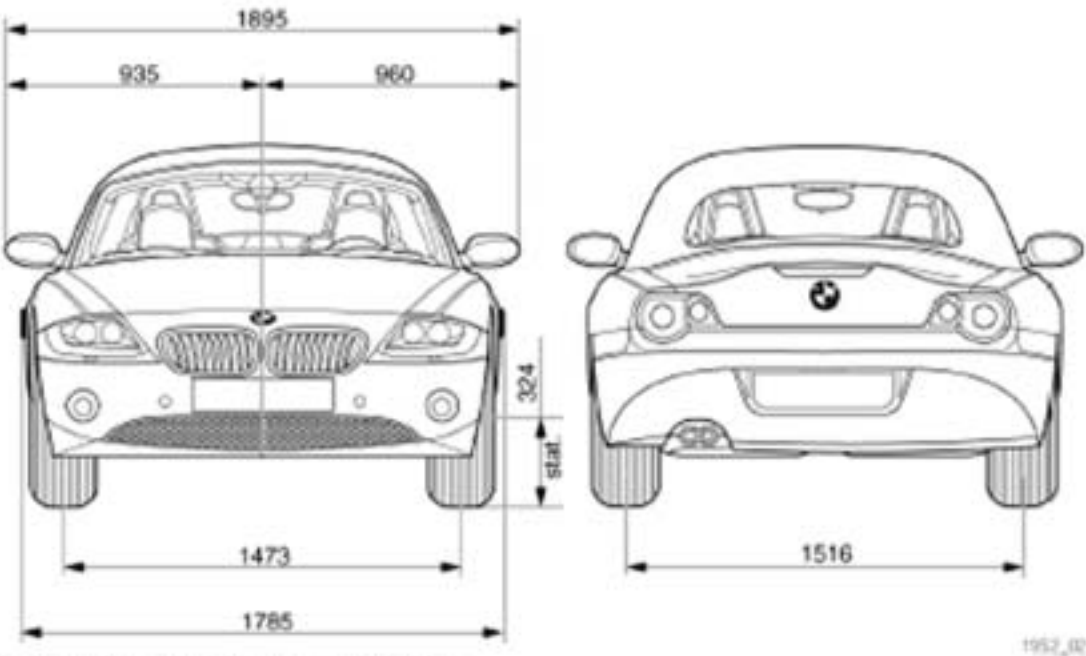
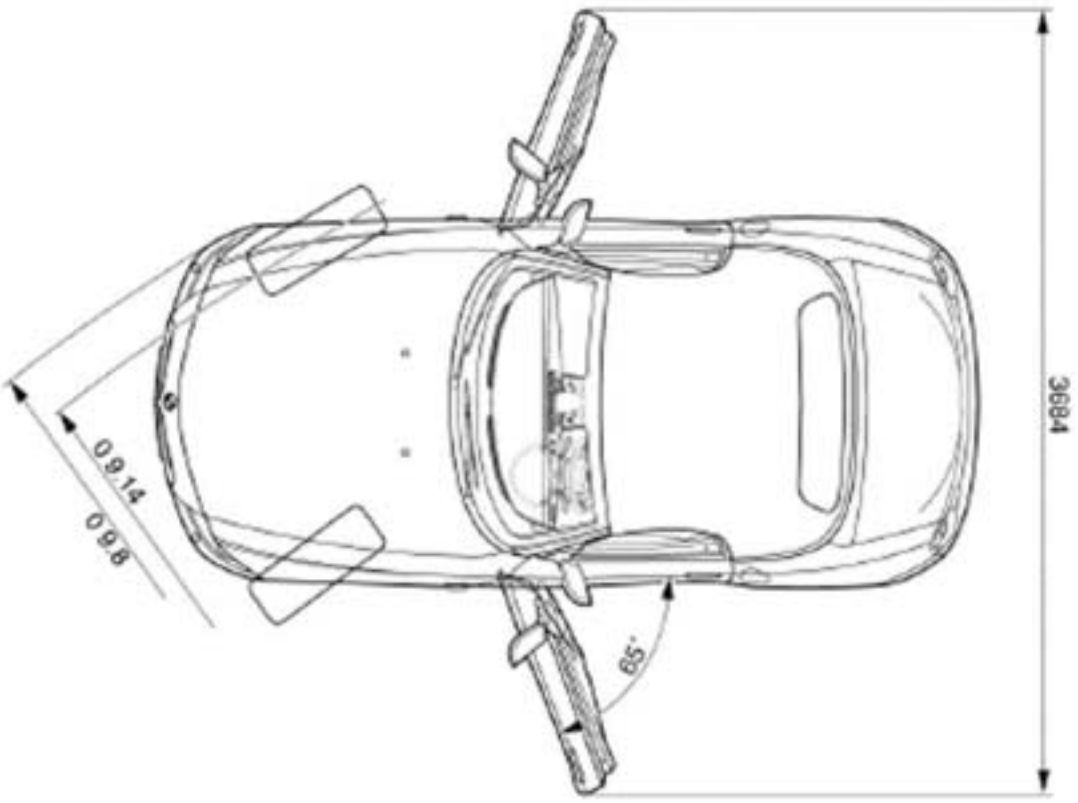

Abb. 19: Garagenzeichnung Klappen, negative Stürze

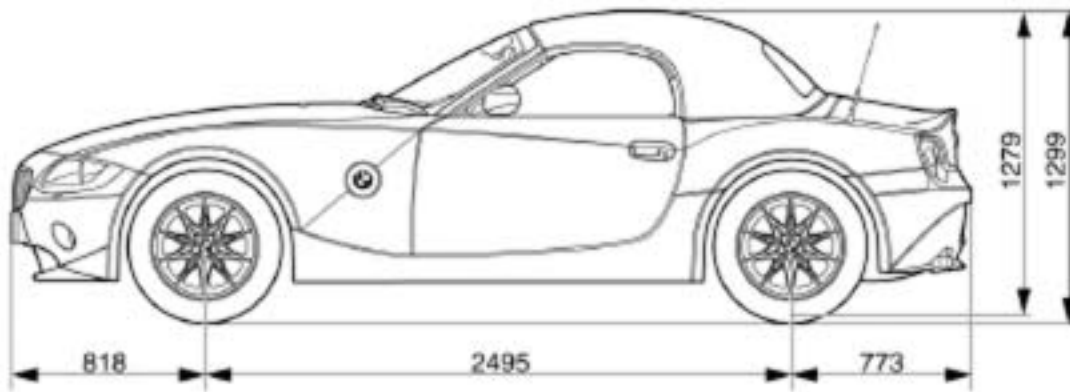

Abb. 20: Garagenzeichnung positiver Sturz

Technical Data

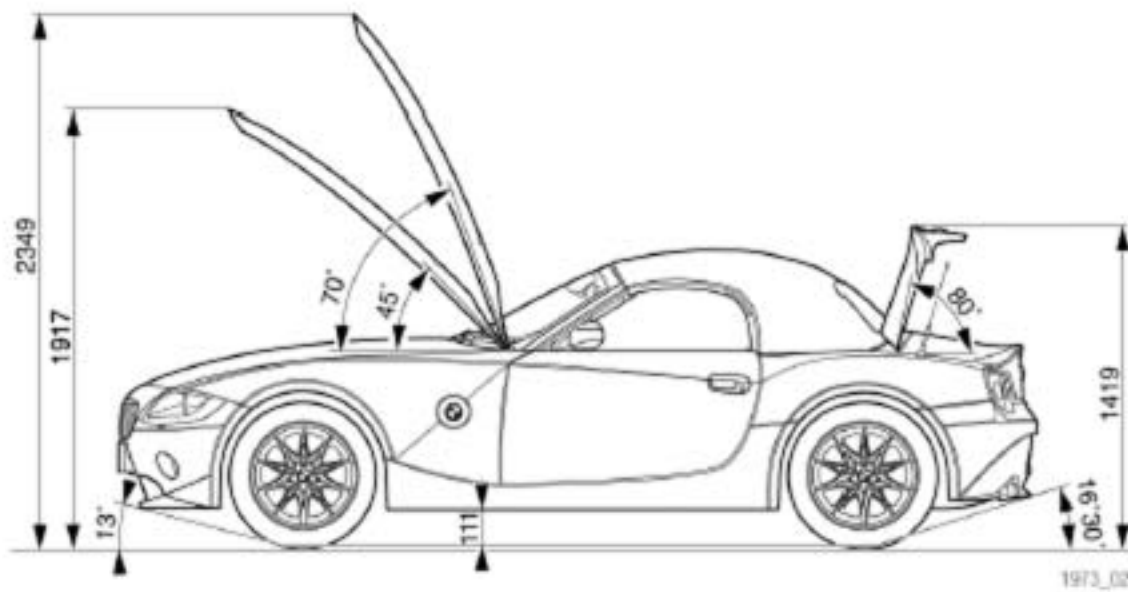
	BMW Z4 3.0i (2.5i)	BMW Z3 3.0i
Length (mm)	4086	4050
Width (mm)	1785	1740
Height (mm)	1299	1293
Wheelbase (mm)	2495	2446
Cylinders/Valves	R6/4	R6/4
Output (HP)	231 (191)	231
At Engine Speed (RPM)	5900 (6000)	5900
Torque (Nm)	300 (245)	300
At Engine Speed (RPM)	3500	3500
0-100 km/h (s)	5.9 (N/A)	6.0
Fuel Consumption (l/100km)	9.2 (N/A)	9.5
Fuel Tank Capacity (l)	55	52
Trunk volume Top Lowered Top Raised	240 260	165 165
Rigidity (hz)	19.5	17.0
Rigidity (Degrees/Nm)	14000	7000
Empty Weight (kg)	1331	1360
Emission Compliance	ULEV (LEV)	ULEV

Body

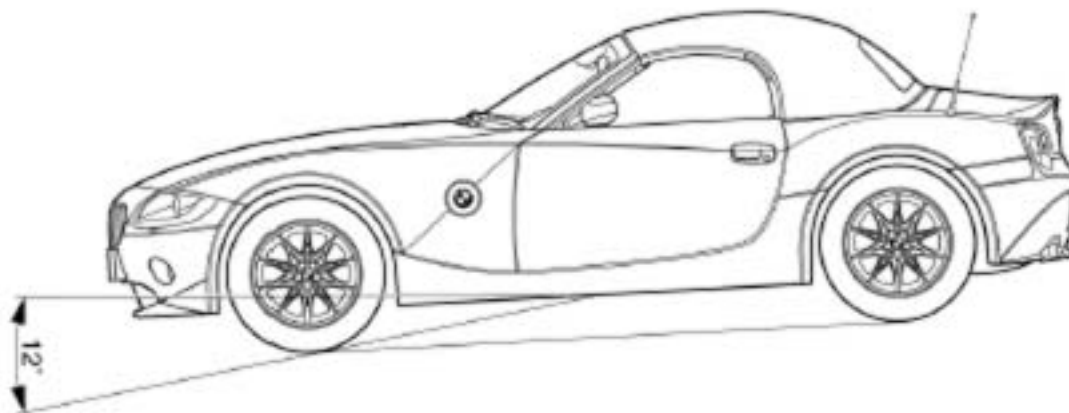
A conventional, roadster-specific steel body with bolted side walls (reduced repair effort in the case of small parking accidents) stands on a completely new sub-frame. Only the engine bonnet is made of aluminum.

The steel structure of the bodyshell is welded from weight-optimized components and carries an integrated rollover bar. The exterior plate of the A-pillar is additionally reinforced, which benefits rigidity in the event of a rollover.

Comparatively long deforming elements (2) are bolted onto the front side members (1), to which in turn the bumper system (3) made of reversible system foam is secured. The deforming elements are matched to the side members as regards shape and diameter, and they achieve a higher level of force than other energy-absorbing systems. This means that, in the event of a high-speed crash, they are more effectively involved in the energy household.

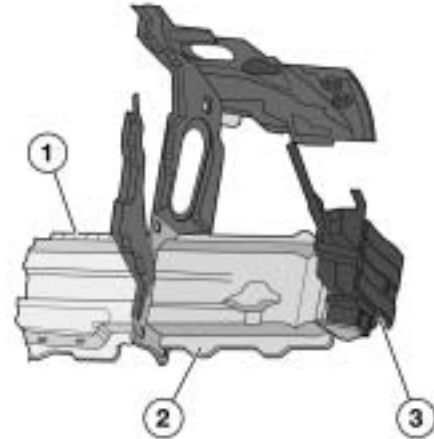

Hood

The bonnet is made of aluminum. It has a service position setting which allows it to be opened to an angle of approx. 90°. The hinges are made of coated steel. The hood can be adjusted by means of buffers.

Headlights

The E85 headlights are fitted with halogen bulbs as standard for both the dipped and main beams. Bi-xenon bulbs are available as an option. The bi-xenon headlights come with automatic beam height adjustment, while the halogen headlights have manual beam height adjustment.

There is a completely new procedure for replacing the bulbs. On the E85, the bulbs are only accessible through a hole in the wheel arch liner.

The headlights are adjusted from inside the engine compartment through the cross-member using an Allen key.

The headlight lenses can not be replaced individually. They are permanently glued to the headlamp unit outer casing.

The headlight beam height positioner can be removed through the open cover when the headlight unit has been removed. Removal of the headlight beam height positioner involves threading it through the joint socket. On the dynamic positioner, the connector can be unplugged; on the manual positioner, the cable has to be cut.

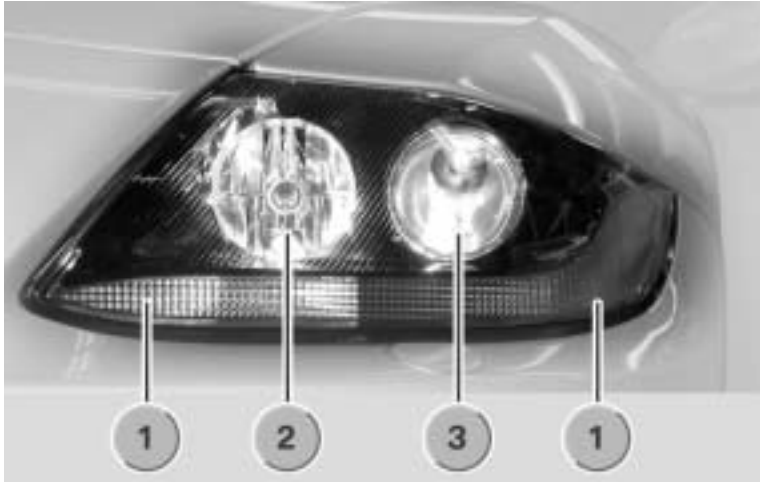

1. Turn Signals
2. High Beam Headlights
3. Low Beam Headlights

1. Vertical Adjustment Actuator
2. Wire Retaining Clip
3. Horizontal Adjuster
4. adjusting Screw
5. Flexible Shaft

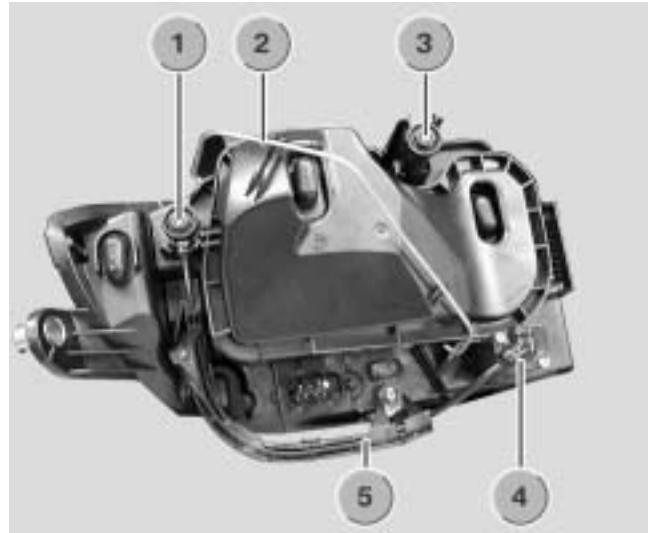

Front bumper

The front bumper system consists of:

- deformation elements
- aluminum cross-member
- impact absorbers
- plastic panel

The individual bumper components can be fitted and removed one at a time in sequence (sandwich construction).

Plastic panel

The bumper plastic panel is a one-piece panel that is painted in the body colour. It clips to the side panels as on the E65 and is bolted to the front bulkhead and the underbody. The kidney grille clips in from the outside.



Service notes

The fog lamps are adjusted by means of the screw that is accessed through the hole above the fog lamps. The towing lug screws into a tapped hole. As on earlier models, the thread is protected by a captive cap painted in body colour.

Impact absorber

The impact absorber is bolted onto the cross-member.

Bumper cross-member

The cross-member is bolted onto the deformation elements.

Deformation elements

The steel shell-design deformation elements are bolted onto the left and right engine subframe side-members. By using a cross-section profile that mirrors and is adapted to the engine subframe members, the deformation elements can absorb a large amount of energy. In the event of a high-speed impact, the shape and length of the deformation elements allows them to absorb the energy and protect the welded bodyshell. This substantially reduces the cost of repairs.

Note:

The bumpers on the US versions prevent damage to the headlamps at collision speeds of up to 4 km/h. On the US version, the aluminum cross-member has a thicker wall.

Front side panels

The front side panels are made of steel and are attached to the body by means of bolts. There is also a side repeater flasher integrated in each side panel. This lamp is not attached by screws. To be removed, the side repeater flasher has to be turned through 90° and can then be taken out.



Windscreen

There are three choices of windscreen available:

- The standard windscreen with green-tinted heat-blocking laminated safety glass
- The optional windscreen with green sun visor strip
- The optional windscreen with green sun visor strip and rain/light sensor

Door mirrors

The door mirrors are screw mounted at three points.

The following types of mirror glass are available as optional extras:

- Electrochromatic mirror glass
- Convex mirror glass

The mirror glass is attached to the mirror positioning motor by a bayonet fixing (1). In order to access that fixing, a small cover has to be unscrewed. The mirror glass can then be removed. The painted mirror body can also be removed separately. This involves first removing the mirror glass and then unscrewing the positioning motor as well. The push-fit mirror body can then be pulled off.

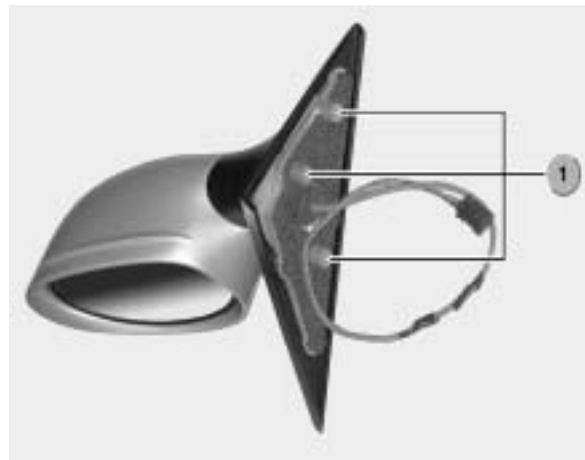

Door trim panel

The door trim panel is attached to the door by screws, clips and catches.

There are four fixing screws:

- One behind the airbag symbol
- One behind the door release grommet
- Two behind the door pull clasp

In addition there are 9 clips. There is sound insulation material glued behind the door trim panel.



1. Grey Clips
2. White Clips

Window regulator/door window glass

The E85 uses a cable-operated window regulator. There are slots, tapers, adjusting and locking screws provided for adjusting the window glass on the X, Y and Z axes.

The door window glass is made of non-laminated safety glass.

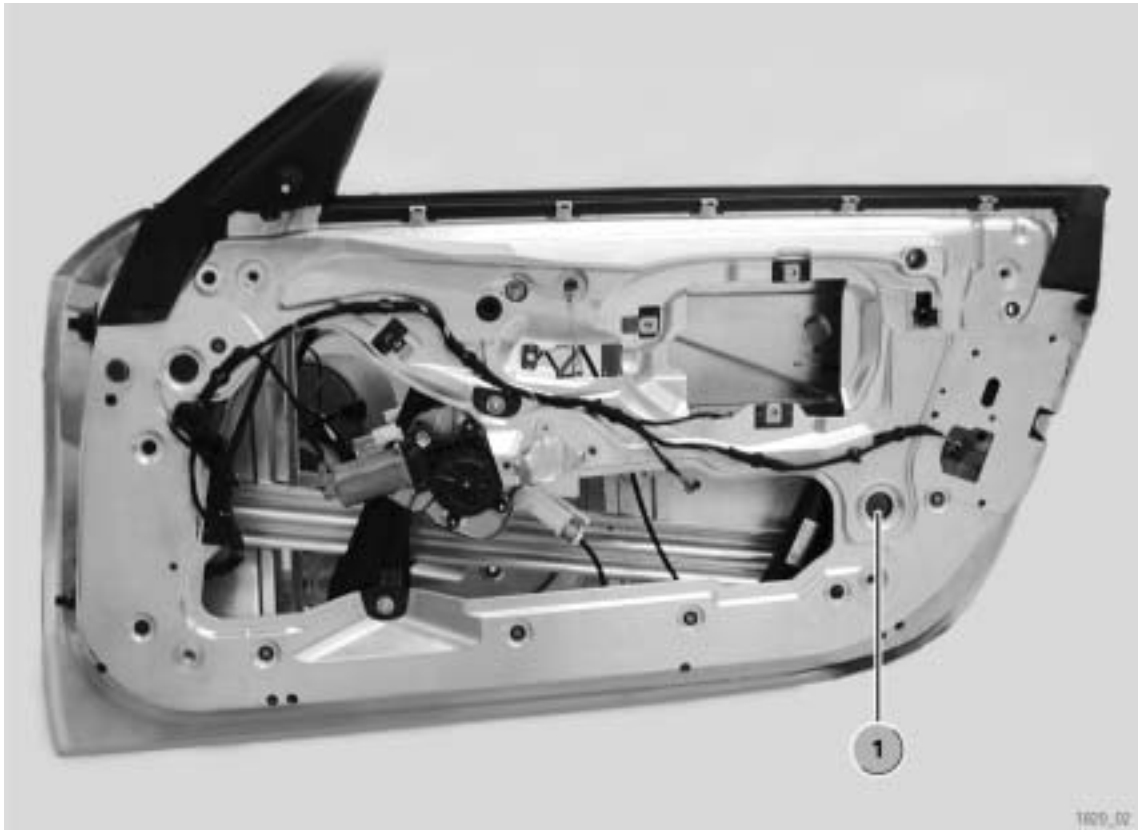

Handle/lock

The exterior handle can be removed by means of a special tool (same design as E39). The lock and the servo motor form a single unit.

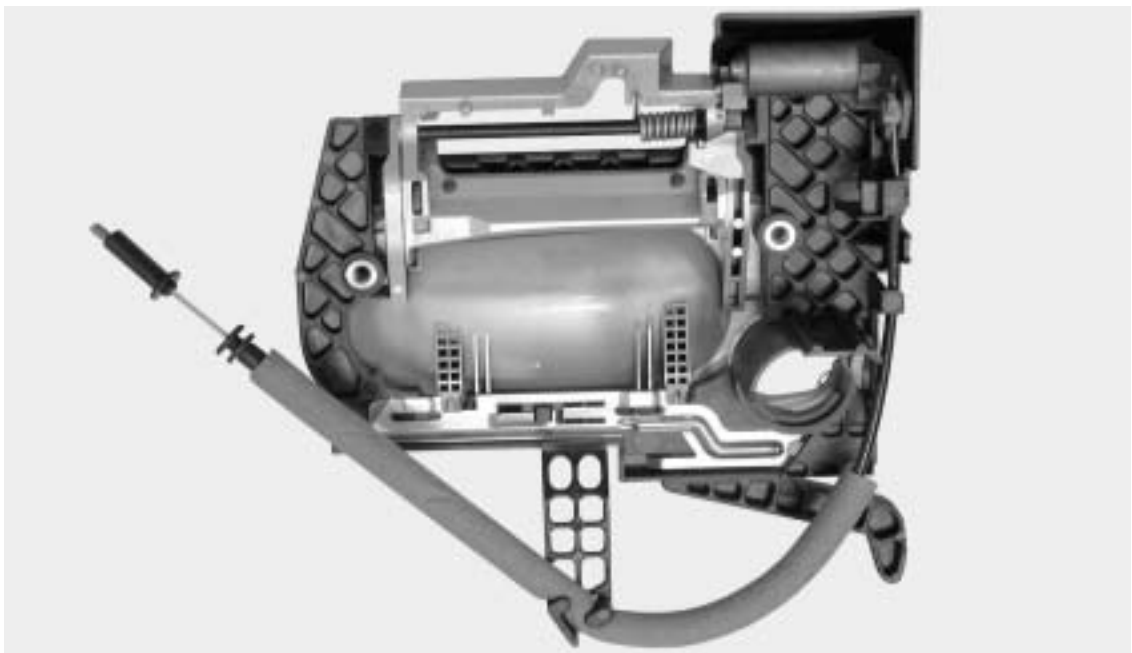

Interior

The E85 is available with the following interior trim options:

- "Free Spirit" recognizable by fabric seats
- "Active Sports" recognizable by fabric/leather combination seats
- "Oregon Leather" full leather seats
- "New England Full Leather" full leather seats with decorative seam in the center
- "Black Artificial Leather" (US only)

Seats

The basic seat in the E85 is essentially the same from a technical point of view as the basic seat in the E46. The design has been modified, however.

Basic seat (electric)

The following features are new:

- The backrests of the basic seats do not fold down.
- The backrest frame is a completely new design. It is slimmer, higher and lighter. The backrest upholstery and the cover are also new.
- The new head restraints have a smaller range of adjustment.
- The seat base has been lowered by 10 mm compared with the E46 in order to achieve a typical roadster sitting position.



The following fabric options are offered:

- Artificial leather: basic seat for US version
- Fabric/artificial leather combination: basic seat for ECE version (Free Spirit)
- Fabric/leather combination: optional extra (Active Sports)
- Oregon Leather: standard on 3.0i model, optional extra on other models
- Gloss leather: "Extended Leather Trim" option (New England leather)

On the US version, the ISOFIX is fitted as standard.

Other optional extras are the electric seat adjustment and the seat heating for driver's seat and passenger seat.

Sport Seat

The M Sports Seat is available as an option.

Control unit locations in passenger compartment

The following Control Units are located in the passenger compartment:

- Instrument Cluster
- Light Switch Center
- CID
- IHKA
- EWS
- EPS
- Steering Angle Sensor
- Center Console Switch Center
- Seat Module
- CVM
- DSC Sensor
- GM V
- Mirror Folding Module



1. A-Pillar Trim Panel
2. EWS Control Unit
3. Electric Servo Motor unit for EPS



1. CID
2. Air Vent
3. CID Control Panel
4. IHKA

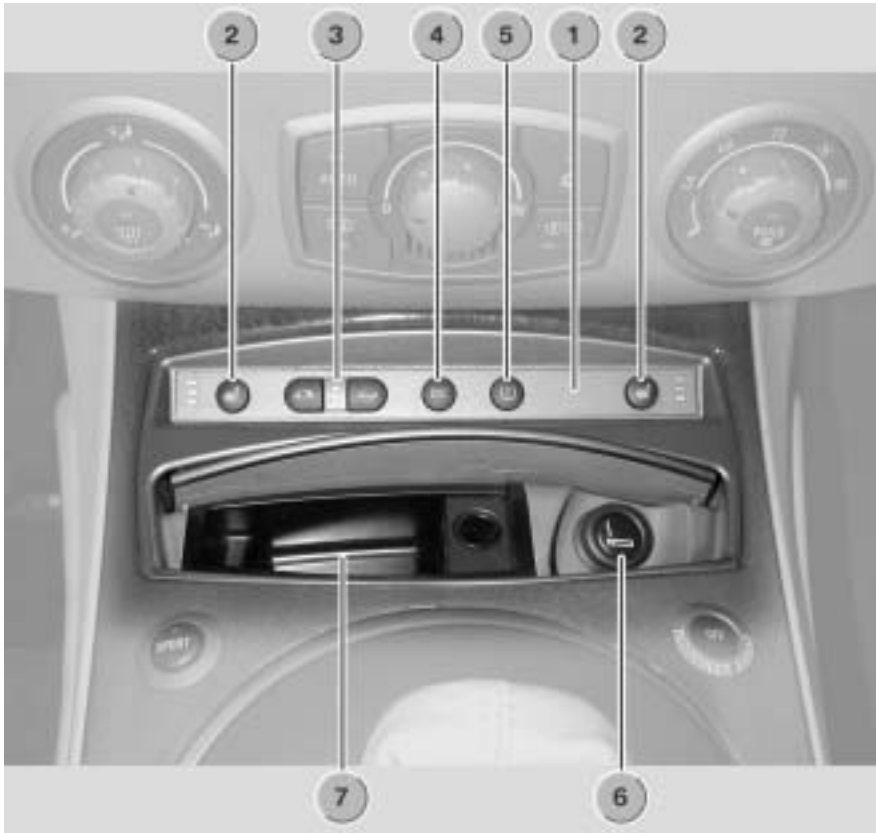

1. Center Console Switch Center
2. Left/Right Seat Heater Buttons
3. Soft-Top Controls w/ LEDs
4. DSC Button
5. RPA Button
6. Cigarette Lighter
7. Ashtray

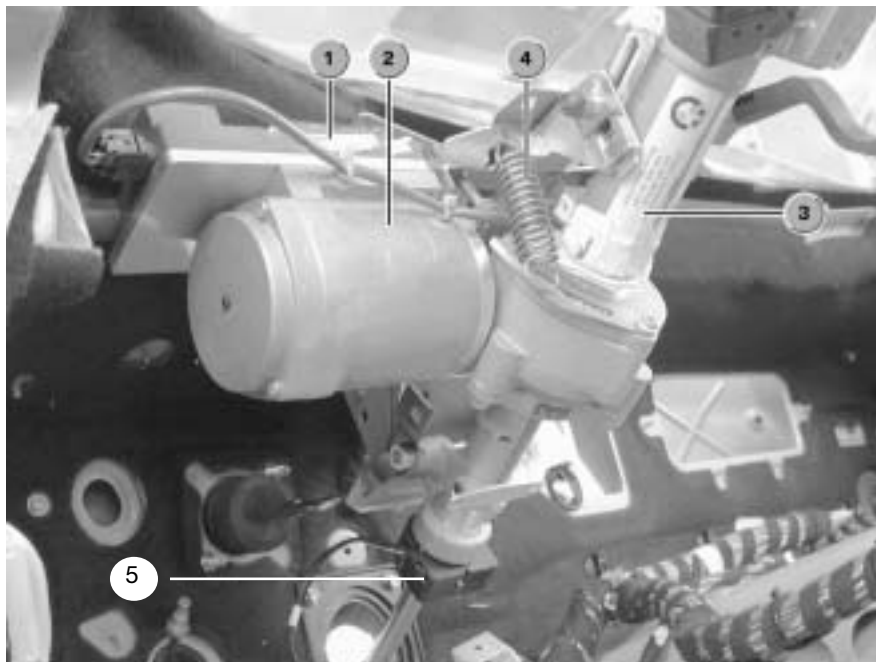

1. EPS Control Unit
2. Electric Servo Motor Unit
3. Steering Column
4. Mass Balance Spring
5. Steering Angle Sensor

Engine compartment Control Units

As usual, there are a number of important control units in the engine compartment. The electronics box on the left at the front contains the DME control unit. Depending on the equipment option chosen, it may also house the EGS (electronic gearbox control) or the SMG (sequential/manual gearbox control) unit. The DSC (Dynamic Stability Control) unit is attached near to the left wheel arch.

A new feature as compared with the Z3 are the suspension-strut mounting cross-braces bolted between the wheel arches and the engine bulkhead.

Locations of control units in engine compartment

The control units of the following important systems are fitted in the engine compartment of the Z4:

- DME (digital engine electronics)
- EGS (electronic gearbox control)
- SMG (sequential/mechanical gearbox control)
- DSC (Dynamic Stability Control)

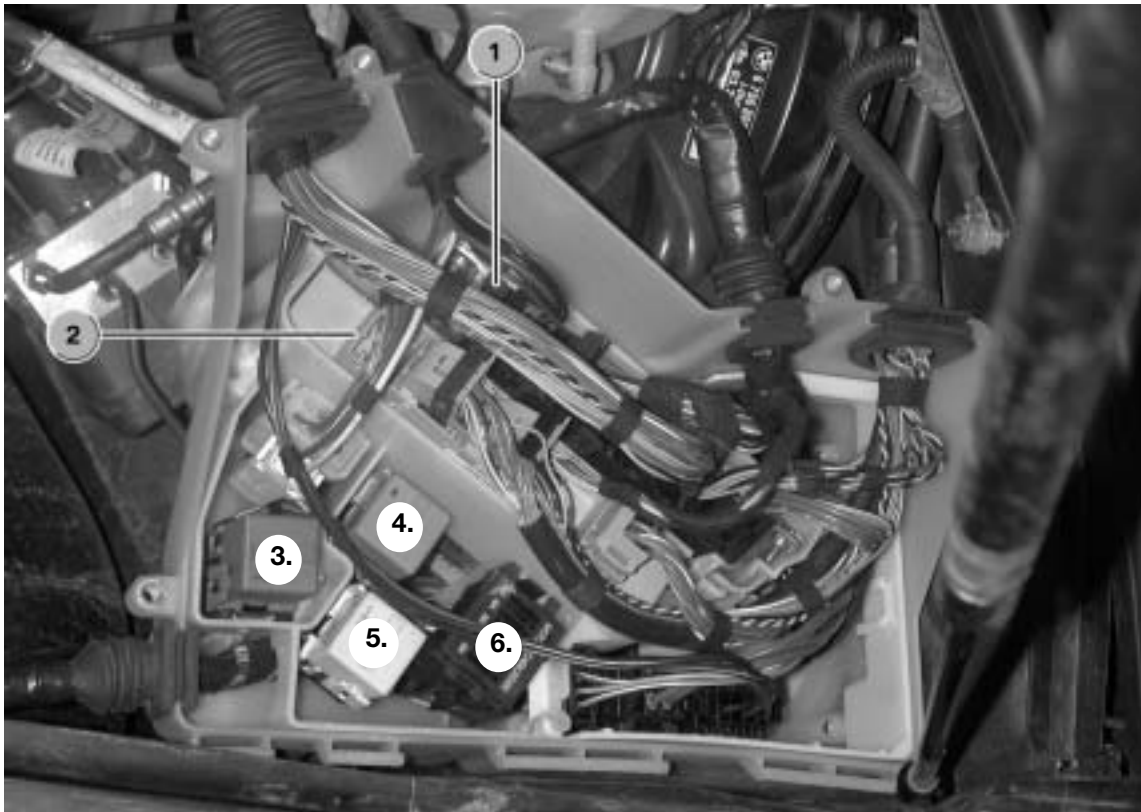

- | | |
|------------------------|-------------------------|
| 1. DME | 2. EGS/SMG Control Unit |
| 3. Back-up Light Relay | 4. DME Relay |
| 5. Fuel Injector Relay | 6. Underhood fuses 1-5 |

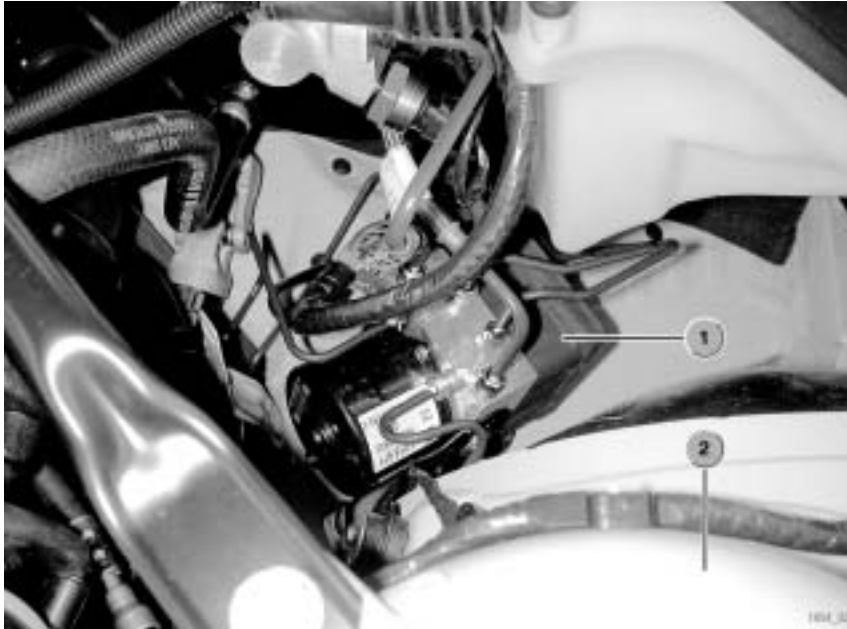

1. DSC Control Unit
2. Wheel Arch

E85 Soft-top

The E85 is available with two soft-top options - manual and fully automatic.

A large number of magnesium and aluminum components have been used in the soft-top frame which combine lightness with safety in the event of an accident. The low soft-top profile offers sufficient headroom.

The natural glass rear window provides optimum transparency. The high-quality impression is retained regardless of the age of the rear window as it no longer gets scratched. The electric rear window heater ensures the window does not mist over.

The "Z" folding action means that the front roof bow simultaneously acts as the stowage compartment cover when the top is lowered. This further simplifies operation of the soft-top as there is no separate stowage compartment cover to be moved. Consequently, there is no need for a soft-top cover (as on E46 Convertible) or a tonneau (Z3).

Manual soft-top

The central soft-top latch for locking it to the windscreen top rail is operated by one hand. This enables the soft-top to be locked easily and ergonomically with one hand.

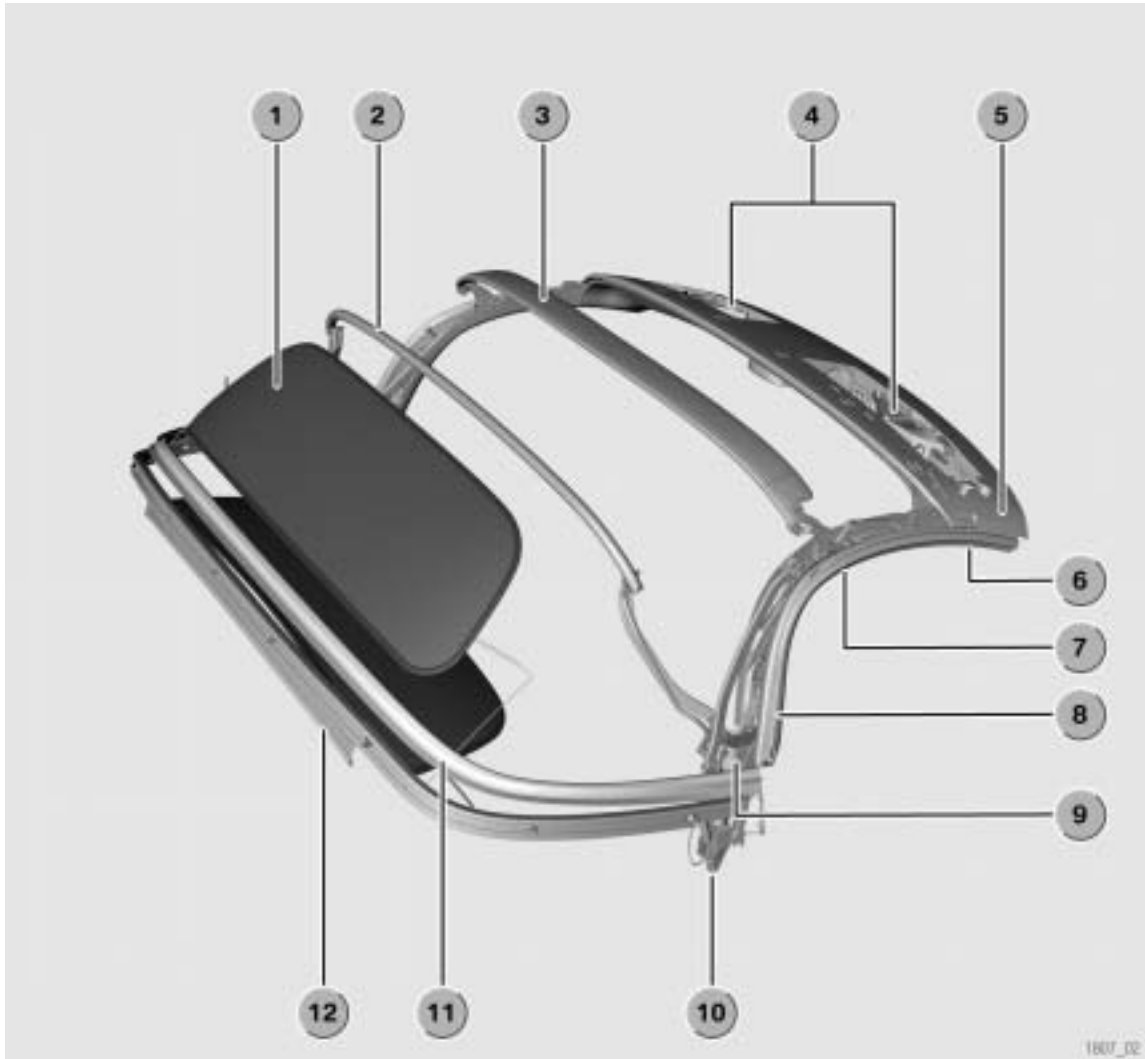

- | | |
|--|--|
| 1. Rear Window (Glass) | 7. Center Pillar Section |
| 2. Corner Rod Bow (Steel) | 8. Main Pillar Section |
| 3. Center Roof Bow (Aluminum) | 9. Main Bearing with Hardtop locating socket |
| 4. Soft Top Latch for Locking to windshield rail | 10. Hydraulic Positioners (Automatic top only) |
| 5. Front roof Bow (Magnesium) | 11. Seal Soft top Stowage Compartment |
| 6. Front Pillar Section | 12. Soft top Bottom Rail (Aluminum) |

Components

20

Complete Vehicle

Soft Top Fabric

The soft-top fabric consists of Twillfast RPC (as on E46/C) and is replaceable. The rear window can only be replaced as part of the soft-top fabric.

Rear window

The rear window is made of natural glass. The rear window is attached to the soft-top fabric by PU foam (as on E46/C) and cannot be replaced separately.

Lowering the soft top

The soft-top is released from the windscreen top rail by hand from the inside using the locking/release handle. The soft-top is then stowed in the stowage compartment and locked in place by the stowage compartment catch. The front roof bow acts as the stowage compartment cover when the soft-top is lowered.

Raising the soft-top

Pressing the button in the rear centre trim panel releases the stowage compartment catch and the soft-top moves upwards slightly by the action of the gas dampers. The soft-top is raised up to the windscreen top rail by hand. The soft-top is locked to the windscreen top rail by hand from the inside using the locking/release handle.

Stowage compartment catch

When stowed in the stowage compartment, the soft-top is held in place by a locking mechanism. The stowage compartment catch is located in the centre of the stowage compartment.

To lock it in place, the manual soft-top has to be pushed down lightly into the stowage compartment by hand. The soft-top centre latch (on the front roof bow) then engages in the stowage compartment catch (2).

Releasing the stowage compartment catch:

Pressing the stowage compartment catch release button (1) releases the catch and the soft-top moves upwards slightly (by the action of the gas dampers on the main bearings). The release button (1) is located on the rear centre trim panel between the two seats and is accessible from inside the vehicle.

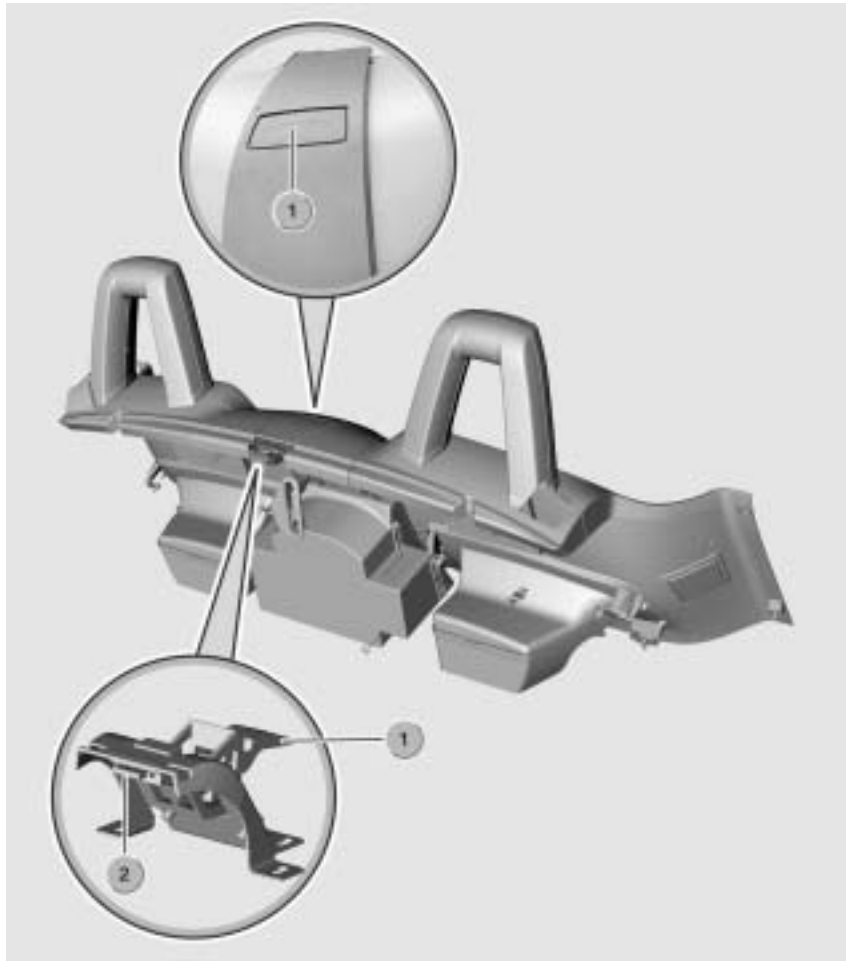

1. Mechanism and Release Button
2. Stowage Compartment Catch

Service notes:

The manual soft-top is available in black only and without inner lining. The soft-top is designed in such a way that it does not have to be removed in the winter.

Ordering spare parts:

The following spare parts can be ordered (same as E46/C):

- Complete soft-top (fabric, inner lining and frame)
- Fabric only
- Frame only

Adjusting the soft-top:

Correct adjustment is provided by adjusting shims. There are factory-fitted adjusting shims under the fixing bolts (M8) on the B-pillar. They ensure the correct lateral gap between the soft-top and the body. When a new soft-top is fitted, the adjusting shims have to be refitted.

Fully automatic soft-top

The fully automatic soft-top, like the standard soft-top, consists of magnesium and aluminum components.

The soft-top lowers and raises fully automatically by means of electrohydraulic servo units that control the primary soft-top movements. The soft-top/windscreen top rail locks are operated by an electric motor.

The soft-top is raised and lowered by pressing the soft-top switch located between the gear lever and the ash tray - no additional manual operations are required.

The inner lining provides a neat, coupé-style interior effect, and significantly improves the soft-top acoustics and heat insulating properties.

The fully automatic soft-top is available as an optional extra.

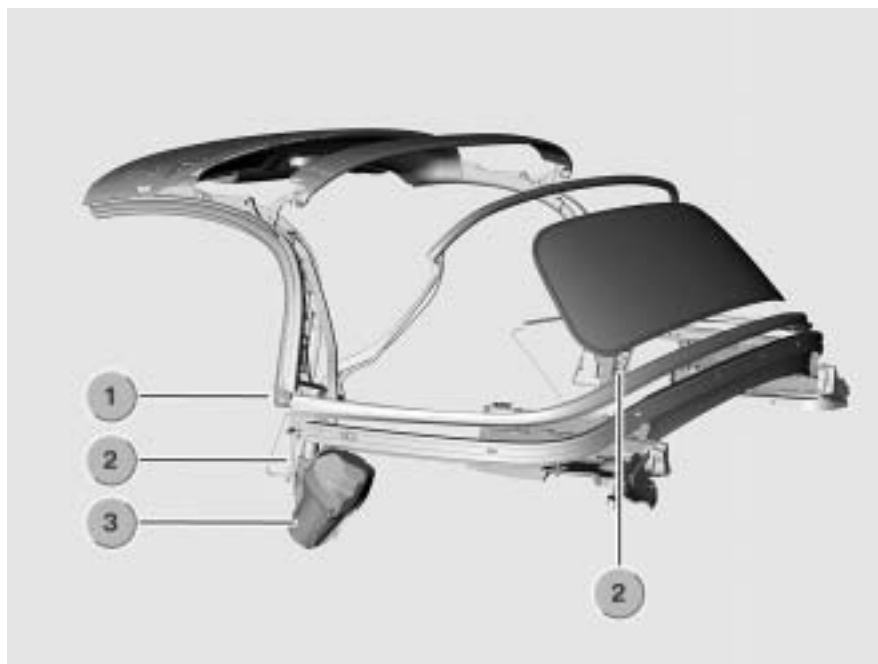

1. Main Bearing
2. Hydraulic Servo Unit
3. Hydraulic Pump Unit

System overview

The hydraulic pump unit is mounted on the left soft-top main bearing.

Hydraulic pump unit

The hydraulic pump unit consists of an oil reservoir with an integral pump. The pump is driven by a DC reversing motor. All hydraulic valves are integrated in the hydraulic pump unit.

Method of operation:

To change the direction of movement of the folding soft-top, the direction of rotation of the hydraulic pump motor is reversed. The hydraulic pump only operates while the soft-top is being moved.

The operation of the pump and locking mechanism are controlled by the CVM IV control unit as required on the basis of the soft-top switch setting.

A temperature sensor protects the hydraulic pump unit against overload. There is a temperature sensor fitted to the hydraulic pump unit (similar to E46/C). At a temperature of 105° Celsius the pump is prevented from operating in order to protect the hydraulic system from damage. The soft-top can then only be operated manually.

There is no facility for topping up the hydraulic fluid on this sealed hydraulic system, nor is it necessary. The hydraulic system has a self-bleeding function which is activated by repeated operation. In order to replace the hydraulic pump unit, the soft-top frame has to be removed.

Hydraulic servo units

The folding soft-top is moved in two directions for lowering and raising by two double-action hydraulic servo units. The hydraulic servo units can only be replaced in conjunction with the soft-top frame as a whole.

There is one hydraulic servo unit on each side of the soft-top frame (in the main pillar) on the main bearings. The hydraulic pump unit is attached to the left hydraulic servo unit.

Preconditions for raising and lowering the soft-top

Before the soft-top can be moved, the following preconditions must be met:

1. Neither window detected as closed by the basic module
2. Vehicle stationary (road speed < 5 km/h)
3. No hardtop fitted
4. Ignition key position at terminal R at least (except for Easy Open/Close function)
5. System test reports no faults
6. No short circuit and no circuit break present
7. Outside temperature is above minimum limit

Preconditions 1 to 7 must be satisfied simultaneously.

Lowering the soft top

Sequence:

1. Windows are lowered (window regulators are operated for 1.5 seconds if a closed window is detected)
2. Soft-top is released from the windscreen top rail
3. Soft-top is folded backwards
4. Soft-top is stowed in stowage compartment and locked in place
5. Locking latches are retracted while pump is still running
6. Red LED goes out
7. Windows are raised (2 seconds after soft-top locks in position)

Raising the soft top

Sequence:

1. Windows are lowered (window regulators are operated for 1.5 seconds if a closed window is detected)
2. Locking latches are extended and the stowage compartment catch is released
3. Soft-top is lifted out of stowage compartment
4. Soft-top is raised forwards
5. Locking latches engage in windscreen top rail
6. Locking mechanism is activated, moves to "LOCKED" position and stops on reaching the limit switch
7. Red LED goes out
8. Windows are raised (2 seconds after soft-top locks in position)

Note:

If the soft-top button is released while the raising or lowering sequence is still in progress, the movement of the soft-top comes to an immediate halt. Because the drive system does not lock, the soft-top is then held only by the inherent resistance within the mechanism and the hydraulic servo units.

Pressing the button again restarts the interrupted movement.

Easy Open function

An automatic sequence of operations for lowering the soft-top can be activated using the ignition key in the driver's door.

Sequence:

1. Insert ignition key in driver's door lock
2. Turn key anti-clockwise and hold. The basic module immediately sends the "Easy Open" signal to the soft-top module.
3. The window regulators are then operated by the CVM control unit within 1.5 seconds. Windows are lowered
4. Remaining sequence as for "Lowering the soft-top", steps 2 to 7

5. Remove ignition key from door

The Easy Open function is not possible after terminal R.

Easy Close function

An automatic sequence of operations for raising the soft-top can be activated by locking the driver's door.

Easy Close sequence:

1. Insert ignition key in driver's door lock
2. Turn key clockwise and hold. The basic module immediately sends the "Easy Close" signal to the soft-top module
3. Remaining sequence as for "Raising the soft-top", steps 2 to 7
4. The window regulators are then operated by the CVM control unit within 1.5 seconds. Windows are closed.
5. Remove ignition key from door

Note:

If the signal from the soft-top module IV is not received, the basic module activates the automatic "Close All" function. The Easy Close function is not possible after terminal R.

Emergency actuator

If the electrics or hydraulics fail, the soft-top can be raised/lowered by means of the emergency actuator.

To raise the soft-top using the emergency actuator, the following procedure must be followed:

- Open bypass circuit on hydraulic pump unit by pulling cable.
- Release soft-top stowage compartment catch by pulling cable.
- Raise soft-top to windscreen top rail by hand.
- Engage windscreen top rail lock using Allen key.

For lowering the soft-top with the emergency actuator, the procedure is reversed.

Opening bypass circuit on hydraulic pump unit:

In the boot on the left-hand side below the soft-top stowage compartment base there is a release cable with a plastic pull handle. The plastic pull handle is pulled out as far as it will go and then locked in that position by turning it through 90°. This opens a bypass circuit in the hydraulic pump unit. The soft-top can then be moved by hand.

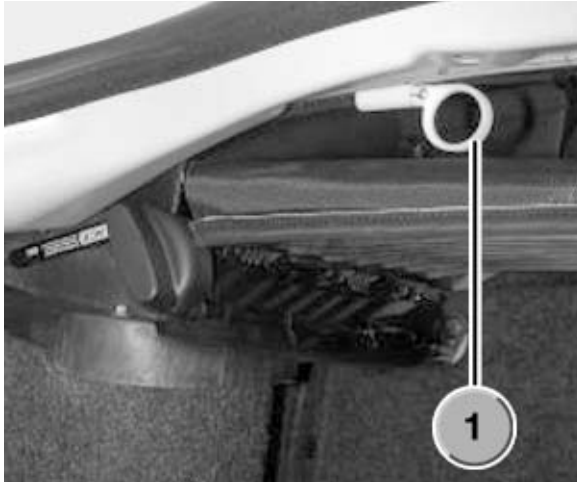

1. Emergency Actuator Release for Hydraulic Unit

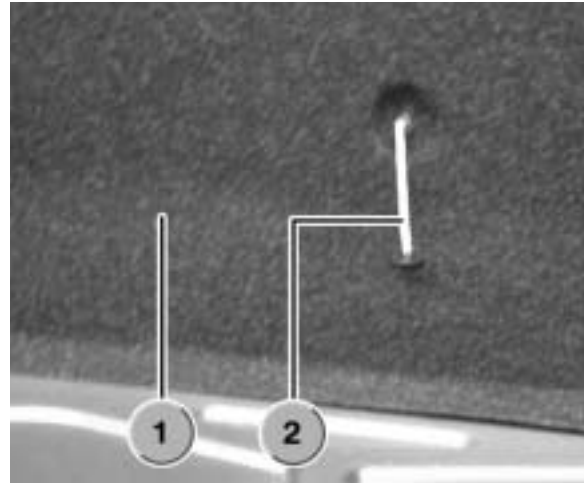

1. Trunk Trim Panel
2. Cable Release for Stowage Compartment

Emergency stowage compartment catch release

The soft-top stowage compartment catch must then be released. This involves pulling the release cable on the rear boot trim panel. The soft-top stowage compartment catch then disengages. The release cable is on the boot bulkhead. Pulling the release cable handle from inside the boot releases the soft-top stowage compartment catch. The soft-top can then be raised up to the windscreen top rail by hand.

Operating the windscreen top rail lock manually:

To lock the soft-top to the windscreen top rail, the plastic trim on the front roof bow must be removed. Below the plastic trim panel is a socket-head bolt. Using the Allen key supplied in the vehicle toolkit, the windscreen top rail lock can then be locked or unlocked manually.

Adjustment after soft-top removal/replacement:

There are factory-fitted adjusting shims under the fixing bolts (M8) on the B-pillar. Those adjusting shims ensure the correct lateral gap between the soft-top and the body.

Variable-position soft-top stowage compartment base

The mechanism of the soft-top stowage compartment base consists of twin hinges with adjuster handles and gas dampers.

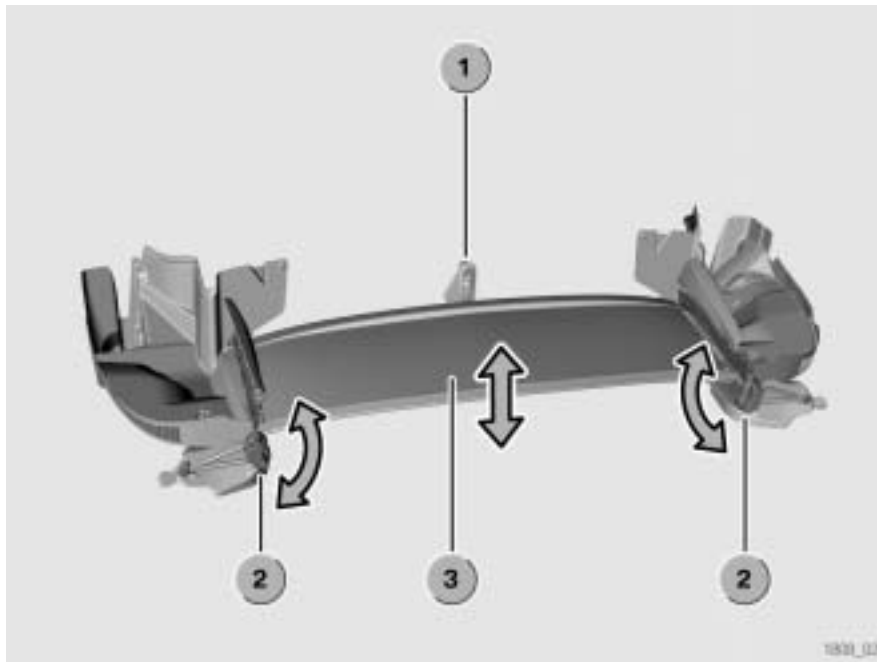

1. Microswitch
2. Adjuster Handles
3. Stowage Compartment Base

The stowage compartment base is at its lowest position when the soft-top is stowed. When the soft-top is raised, the variable-position soft-top stowage compartment base (3) can be manually raised to the upper position from inside the boot. This provides additional boot space so that bulky items such as drinks crates, golf bags, etc. can then be carried. The soft-top can only be lowered when the stowage compartment base is at its lowest position. So that the position of the stowage compartment base can be automatically detected, there is a microswitch (1) fitted to it.

The stowage compartment base can be moved to the upper or lower position by turning the adjuster handles (2). Gas dampers incorporated in the two stowage compartment base mechanisms hold the stowage compartment base at the respective limits of movement.

Index Explanation

Hardtop

The hardtop on the E85 is similar in design to the E36/7 version.

The hardtop consists of the following components:

- Hard shell with bolt-on spoiler
- Interior trim (inner lining)
- Centering bolts/centering and securing bolts
- Attachment locks with mechanism
- Covers for centering and securing bolts
- Special fitting tool

Wind-break

The wind-break substantially reduces the draught in the passenger compartment when the soft-top is down. The wind-break (2) fits into locating recesses between the two roll-over bars. The locating recesses are integrated in the rollover bar trim panels. The wind-break can be removed when not in use and stored in the boot lid.

Roll-over bar trim panels

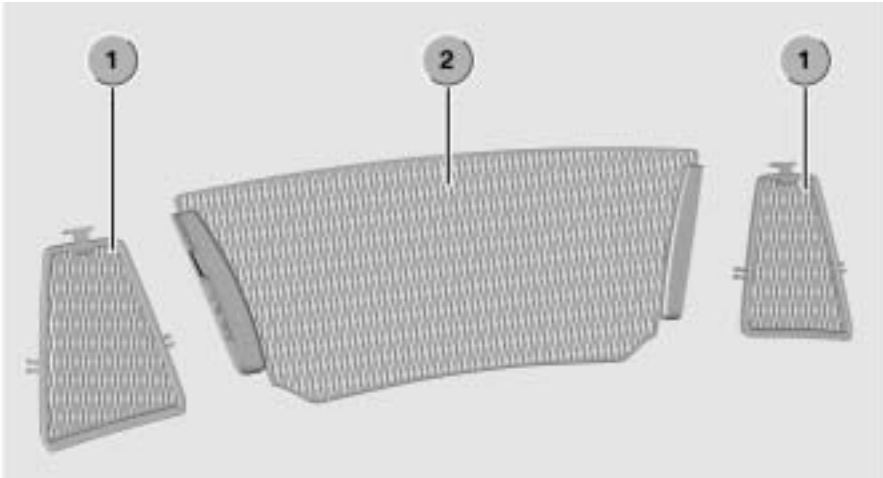

- 1. Mesh inserts for Roll bars
- 2. Mesh insert In-Between Roll Bars

There are locating recesses for the wind-break integrated in the roll-over bar trim panels. The roll-over bar trim panels contain mesh inserts (1). Each roll-over bar trim panel consists of two parts which are snap-fitted onto the roll-over bars.

Note:

The wind-break can be ordered as an optional extra with the vehicle. As the fixings for the wind-break are integrated in the roll-over bar trim panels, if the wind-break is fitted at a later date, the standard roll-over bar trim panels must be replaced with ones that incorporate the wind-break fixings.

Trunk

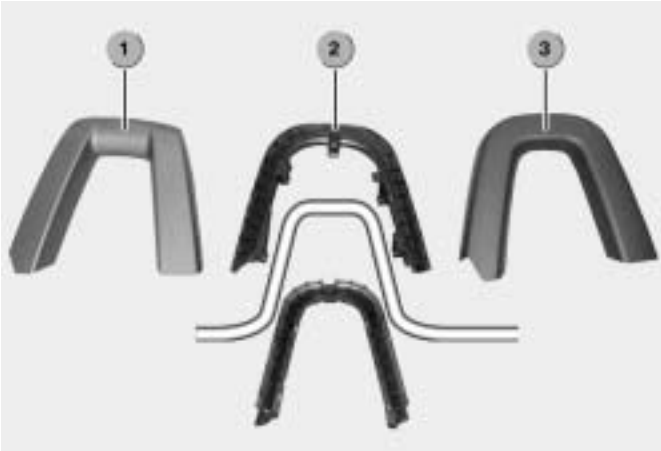

- 1. Front Trim Panel
- 2. Impact Absorber
- 3. Rear Trim Panel

The following control units are located in the boot on the E85:

- HiFi amplifier/Top HiFi amplifier (DSP amplifier)
- AMPS compensator (USA only)
- PDC control unit
- Fuel tank leakage diagnostic module (USA only/boot under vehicle)



1. HiFi Amplifier



1. Wheel Arch Trim
2. PDC Control Unit



1. DM-TL

Rear bumper

The rear bumper system consists of:

- 2 impact dampers (US version)
- One cross-member
- 2 impact absorbers
- A plastic panel

Impact dampers (US version)

The impact dampers to which the bumper cross-member is attached collapse by about 30 mm into the chassis side members in the event of an impact.



Plastic panel

The thermoplastic bumper panel is painted in the body colour.

The license plate holder is attached to the plastic bumper panel by two dome-head screws designed for use with thermoplastic components. The cut-out for the towing eye is covered by a captive cap painted in body colour.



Park Distance Control (PDC)

PDC is available as an optional extra on the EU models. The 4 PDC sensors are push-fitted in the rear plastic bumper panel. There are 8 cable clips provided for routing the wiring.

Sidemarkers (US)

In addition to the differences already referred to regarding the aluminum cross-member with impact dampers and impact absorbers, the plastic bumper panel of the US version has two integral sidemarker lamps (1). They are illuminated by LEDs.

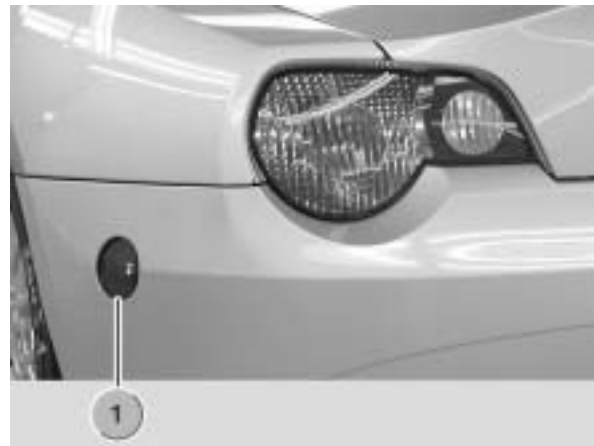

Rear light clusters

The rear light clusters are attached to the rear end panel from the outside by three bolts (6 mm). Between the light cluster and the body there is a seal. The rear light clusters combine the tail light, brake light, reversing light, rear fog lamp (EU), reflector and direction indicator functions.

In the centre of the rear light cluster there is a body-colour decorative strip. It is attached to the light cluster lens by a double-sided adhesive strip.

The bulbs are replaced from inside the boot.

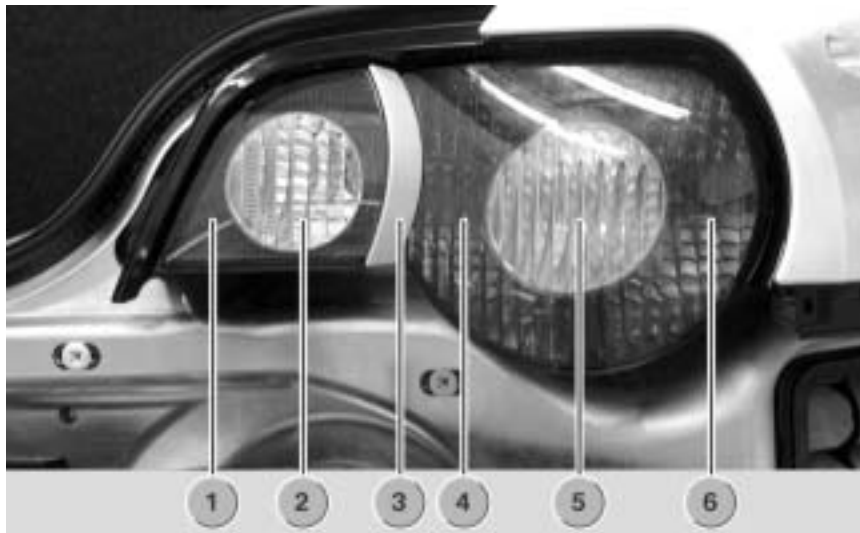

1. Reflector
2. Back-up Light
3. Decorative Strip
4. Tail Light/Brake Light
5. Turn Signal Light
6. Tail Light/Brake Light

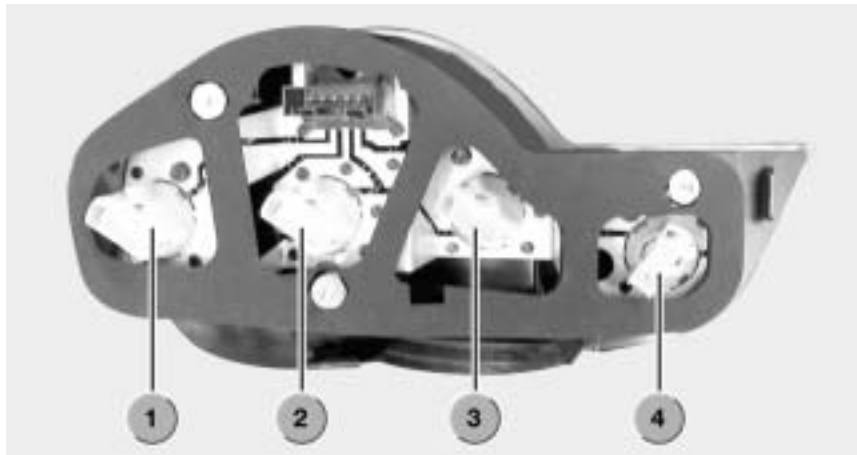

1. Tail Light/Brake Light
2. Turn Signal Light
3. Tail Light/Brake Light
4. Back-up Light

Rear light cluster surround

Around the rear light clusters is a surround painted in body colour. It is attached to the rear light cluster by means of retaining lugs and screws to the body together with the light cluster.

Third brake light

The third brake light is integrated in the boot lid on the E85. It consists of an LED array that can only be replaced as a complete unit.

